

# 2520- EC Motor Speed Controller

# JencoFan

6393 Powers Avenue  
 Jacksonville, Florida 32217-2298  
 P: 904.731.4711 / F: 904.737.8322  
 www.Jencofan.com

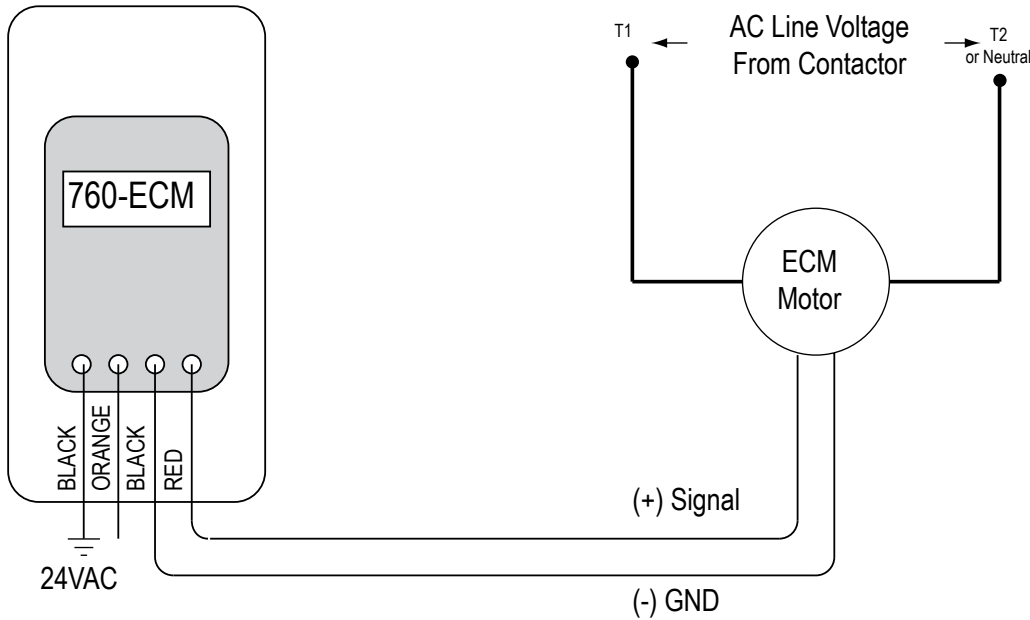

## Features

- Motor Types: ECM (dc brushless) Motors
- Motor Speed: Field Adjustable
- Input Voltage: 24VAC (+20%/ -10%)
- Output: 0% to 100% PWM @ 80 Hz
- 13.5 VDC, 5mA (max)
- Max Wire Length (twisted pair) 100ft
- Humidity: 95%, Non Condensing
- Ambient: 32-120 F
- Dimensions (LxWxH): 4.25" x 2.40" x 1.25"

**⚠ CAUTION**

If a ground reference is applied to the 24 VAC power source, the "grounded" lead must be connected to terminal 24V COM ONLY

ACCESSORY MODEL	1	2	3	4	5	REMARKS

PROJECT: \_\_\_\_\_ CONTRACTOR: \_\_\_\_\_  
 LOCATION: \_\_\_\_\_ REVISION DATE: \_\_\_\_\_  
 FORM NO.: \_\_\_\_\_ SUBMITTED BY: \_\_\_\_\_ DATE: \_\_\_\_\_  
 ENGINEER: \_\_\_\_\_ APPROVED BY: \_\_\_\_\_ DATE: \_\_\_\_\_

For more information contact us at 1.800.961.7370 for additional submittal drawings.

JencoFan will not be responsible for fabrication changes or errors resulting from customer use of a non-current submittal drawing.

# 2521- Potentiometer Speed Control

# JencoFan

6393 Powers Avenue  
Jacksonville, Florida 32217-2298  
P: 904.731.4711 / F: 904.737.8322  
www.Jencofan.com

Soler&Palau  
Ventilation Group



**Dimensions (LxWxH):** 3.25" x 3.25" x 2.5"

## Features

The Potentiometer 0-10V speed control can be factory mounted to the fan or shipped loose for remote speed control of JencoFan EC motors.

When installed in the fan housing, the Potentiometer is installed in a standard 2X4 electrical junction box.

If remote mounting is desired, the control is shipped loose and can be mounted with the supplied electrical enclosure.

The 10V power supply to operate the speed control is provided by the EC motor and no additional accessories are required with the exception of the low voltage control wire to span the distance from the control to the fan motor.

ACCESSORY MODEL	1	2	3	4	5	REMARKS

PROJECT: \_\_\_\_\_ CONTRACTOR: \_\_\_\_\_  
 LOCATION: \_\_\_\_\_ REVISION DATE: \_\_\_\_\_  
 FORM NO.: \_\_\_\_\_ SUBMITTED BY: \_\_\_\_\_ DATE: \_\_\_\_\_  
 ENGINEER: \_\_\_\_\_ APPROVED BY: \_\_\_\_\_ DATE: \_\_\_\_\_

For more information contact us at [www.jencoFan](http://www.jencoFan) for additional submittal drawings.

JencoFan will not be responsible for fabrication changes or errors resulting from customer use of a non-current submittal drawing.

# 2522 - eRED Constant Pressure System

# JencoFan

6393 Powers Avenue  
 Jacksonville, Florida 32217-2298  
 P: 904.731.4711 / F: 904.737.8322  
 www.Jencofan.com

Soler&Palau  
 Ventilation Group



## NEMA 3R Enclosure for Indoor or Outdoor Mounting

Dimensions: (H x W x D) 8" x 8"x 4"  
 Input: 115/208/230 V Single Phase  
 Output: 0-10 V

### Components

Electrical:	Mechanical:
24V Transformer	Brass Positive Pressure Port
Differential Pressure Transducer	Brass Atmospheric Pressure Vent
EC Motor Control Module	Stainless Steel Pressure Probe

ACCESSORY MODEL	1	2	3	4	5	REMARKS

PROJECT: \_\_\_\_\_ CONTRACTOR: \_\_\_\_\_  
 LOCATION: \_\_\_\_\_ REVISION DATE: \_\_\_\_\_  
 FORM NO.: \_\_\_\_\_ SUBMITTED BY: \_\_\_\_\_ DATE: \_\_\_\_\_  
 ENGINEER: \_\_\_\_\_ APPROVED BY: \_\_\_\_\_ DATE: \_\_\_\_\_

For more information contact us at 1.800.961.7370 for additional submittal drawings.

JencoFan will not be responsible for fabrication changes or errors resulting from customer use of a non-current submittal drawing.

# INSULATED CANTED ROOF CURB NON-PROPELLER PRODUCTS



6393 Powers Avenue  
Jacksonville, Florida 32217-2298  
P: 904.731.4711 / F: 904.737.8322  
www.Jencofan.com

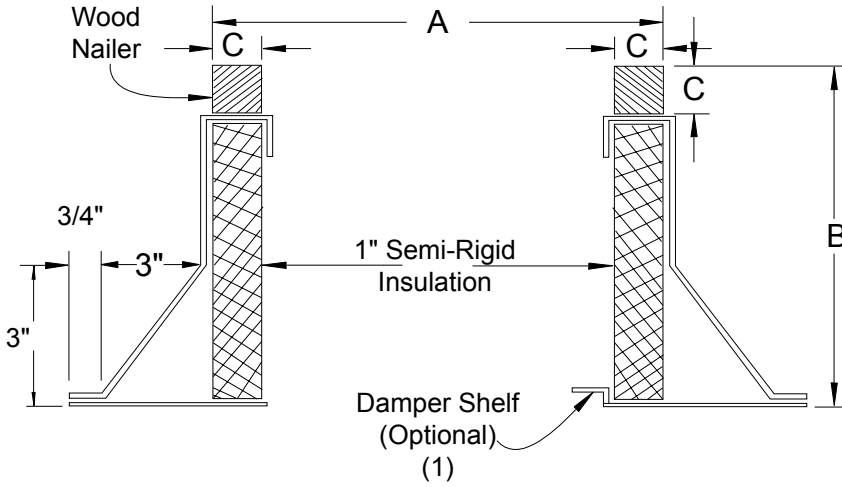

**OPTIONS:**

1. Damper Shelf.
2. Metal Liner - solid or screen type.
3. Burglar bars - 1/2" dia. on 6" centers.
4. Finishes - baked or air-dried enamel or epoxy.
5. Heights: 8, 12, 16, 18, 20, 24" or special heights.
6. Single pitch or double pitch.
7. Aluminum construction.
8. Standard curb is "RF" roof over type.  
("SF" available upon request)

FAN SIZE	"A" OD (Square) CURB				DB		"B" CURB HEIGHT	"C" WOOD NAILER
	TXB	TXD	RCX11	RED / LPD	FAN SIZE	CURB OD "A"		
6	-	14-3/4	-	14-3/4	6	14-3/4	12" STD	1-1/2" Sq
8	14-3/4	14-3/4	14-3/4	14-3/4	8	14-3/4		
10	14-3/4	14-3/4	14-3/4	14-3/4	9	14-3/4		
12	22-1/4	22-1/4	22-1/4	22-1/4	11	22-1/4		
15	22-1/4	22-1/4	22-1/4	22-1/4	12	22-1/4		
18	27-3/4	-	27-3/4	-	14	22-1/4		
20	-	-	27-3/4	-	16	22-1/4		
24	33-3/4	-	33-3/4	-	18	27-3/4		
26	-	-	33-3/4	-	20	27-3/4		
30	40-3/4	-	40-3/4	-	24	33-3/4		
33	-	-	40-3/4	-	30	40-3/4		
36	40-3/4	-	40-3/4	-	36	40-3/4		
42	53-1/4	-	-	-	42	53-1/4		
48	53-1/4	-	-	-	48	53-1/4		

1. Damper shelf opening to be 1" less than damper size. Shelf must be specified if required. ROOF OPENING
2. All curbs are 18 gauge G-90 galvanized steel with continuous seams. Curb O.D. (A Dimension) Less 3.25 inches
3. See current curb submittal for all propeller fan roof curbs.

ACCESSORY ITEMS	1	2	3	4	5	ACCESSORY ITEMS	1	2	3	4	5
<input type="checkbox"/>						<input type="checkbox"/>					
<input type="checkbox"/>						<input type="checkbox"/>					
<input type="checkbox"/>						<input type="checkbox"/>					
<input type="checkbox"/>						<input type="checkbox"/>					
<input type="checkbox"/>						<input type="checkbox"/>					

Project: \_\_\_\_\_ Submitted: \_\_\_\_\_  
 Customer: \_\_\_\_\_ Approved: \_\_\_\_\_  
 Location: \_\_\_\_\_

# TYPE SF SELF-FLASHING CURB

# Jencofan

6393 Powers Avenue  
Jacksonville, Florida 32217-2298  
P: 904.731.4711 / F: 904.737.8322  
www.Jencofan.com

Soler&Palau  
Ventilation Group

## STANDARD FEATURES

- Constructed of 18 ga. galv. steel with continuous welded seams and integral base plate for water tightness and extra strength.
- Wide base flashing to insure adequate bond to roofing surface for water tight seal to roof.
- Lined with 1-1/2" fire proof sound attenuating thermal insulation.
- Top of curb covered with 1/4" polystyrene gasket for weather seal and to reduce metal to metal conducted noise.

PROJECT	
LOCATION	
ARCHITECT	
ENGINEER	
CONTRACTOR	
SUBMITTED BY	
DATE	P.O. NO.

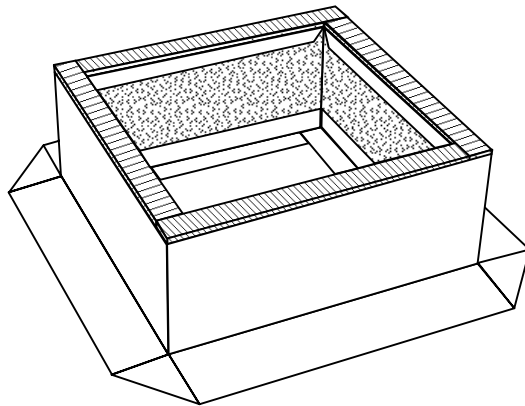
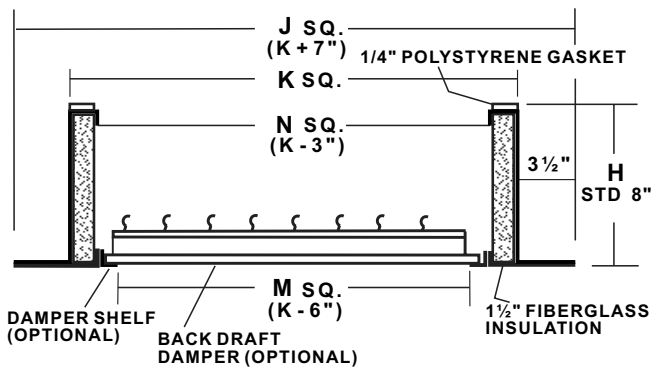

## OPTIONS

- Constructed of .063" aluminum.
- Interior metal liner.
- Standard heights of 12, 14, 16, 18, 20, 24", or any special height.
- Damper shelf - standard or custom size opening.
- Wide flange (6" or 8" wide).
- Backdraft damper.
- Protective or decorative coatings.
- Heavy-gauge construction.

## SPECIFICATIONS AND DIMENSIONS

REFERENCE	QUANTITY	GALV. OR ALUM.	K	N	M	H	OPTIONS

**CURB CAP ADAPTOR  
SPUN PRODUCTS ONLY  
(+ or - 4 inches)  
Square ONLY - NO Rectangles**

**Jencofan**

6393 Powers Avenue  
Jacksonville, Florida 32217-2298  
P: 904.731.4711 / F: 904.737.8322  
www.Jencofan.com

Soler&Palau  
Ventilation Group

**STANDARD FEATURES**

- Heavy-gauge aluminum construction with continuous welded seams for water tightness and extra strength.

PROJECT	
LOCATION	
ARCHITECT	
ENGINEER	
CONTRACTOR	
SUBMITTED BY	
DATE	P.O. NO.

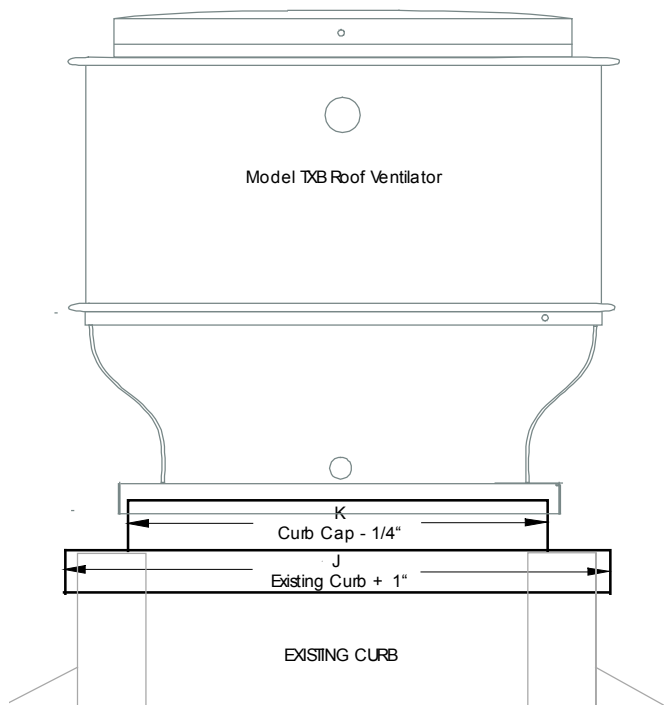

**K - MEASUREMENT**  
1/4" LESS THAN FAN BASE

**J - MEASUREMENT**  
1" LARGER THAN EXISTING CURB O.D.

SPECIFICATIONS AND DIMENSIONS				
REFERENCE	QUANTITY	K	J	OPTIONS

# CURB HINGE ACCESSORY

# JencoFan

6393 Powers Avenue  
 Jacksonville, Florida 32217-2298  
 P: 904.731.4711 / F: 904.737.8322  
 www.Jencofan.com

Soler&Palau  
 Ventilation Group

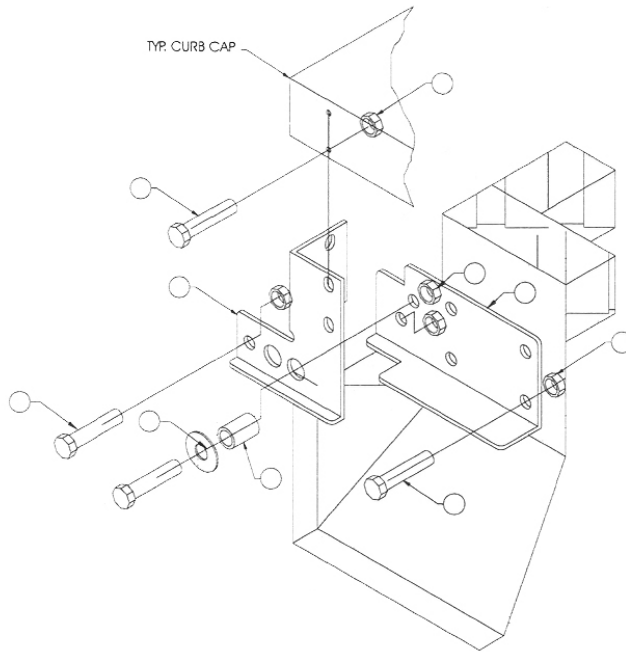

ITEM #	PART #	DESCRIPTION	QTY	ITEM #	PART #	DESCRIPTION	QTY
1	634012	3/8" Flat Washer	2	6	90005802	Hinge Bracket Left Half	1
2	634025	3/8-16 Loknut	2	7	90005101	Curb Hinge Bracket Right	1
3	603656	3/8 x 1-1/4" Long Spacer	2	8	634002	5/16-18 x 3/4 Hex Bolt	16
4	634138	3/8-16 x 2" Long Bolt	4	9	634027	5/16-18 Flange Nut	16
5	90005702	Hinge Bracket Right Half	1	10	90005201	Curb Hinge Bracket Left*	1
				11	634028	13/8-16 Flange Nut	2

\*Items on opposite side, not shown

**Note:** Curb cap needs to be 1/2" minimum larger than the roof curb or roof curb adaptor to allow for bolt head clearance and curb cap tilting around the roof curb or roof curb adaptor.

1. With fan in place on roof curb, locate the hinge cap on both end, mark the holes for 5/16" diameter bolts, drill (8) 11/32" diameter holes at the marked locations.
2. Attach the hinge cap (items 6 & 7 ) to curb cap or fan using (8) 5/16" bolts & flanged nuts, locate bolt head on the inside of the curb cap.
3. With unit in place on roof curb, align curb hinge on roof curb or curb cap adaptor as shown and mark the (8) locations in the roof curb or curb adaptor\*\*.
4. Drill (8) 11/32" diameter holes in previously marked hole locations.
5. Attach curb hinge to roof curb using (8) 5/16" diameter bolts.
6. You can now tilt the fan open about 60°, use the 3/8" bolt to lock the fan in place and prevent it from tipping or slamming shut.
7. Remove the locking bolt when closing back the fan in place, store the bolt next to the fan for future openings or locks.

**CAUTION:** Make sure to remove grease box (if applicable) when tilting the fan to prevent any spillage.

\*\* Two hinge pivot holes are provided in the curb hinge to allow the curb hinge to be mounted higher or lower on the roof curb as required.

# BACKDRAFT DAMPER FOR ROOF MOUNTED AND INLINE CENTRIFUGAL/PROPELLER EXHAUST FANS

# JencoFan

6393 Powers Avenue  
Jacksonville, Florida 32217-2298  
P: 904.731.4711 / F: 904.737.8322  
www.Jencofan.com

Soler&Palau  
Ventilation Group

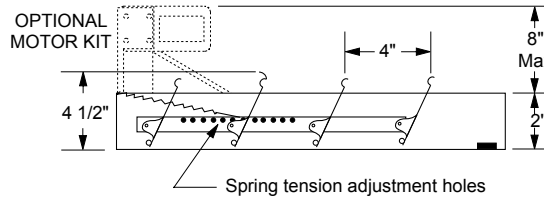
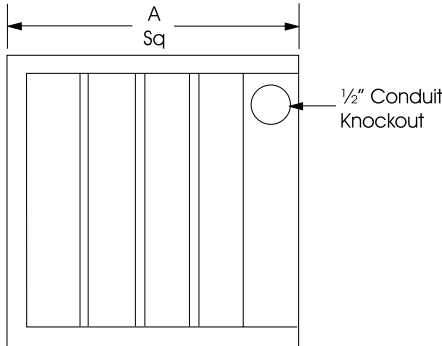

AIR FLOW

**CAUTION:** Motor kits are not suitable for use in explosive or flammable areas or airflows.

For low velocity (CFM) field adjustment of spring tension may be required to ensure that damper blades open completely.

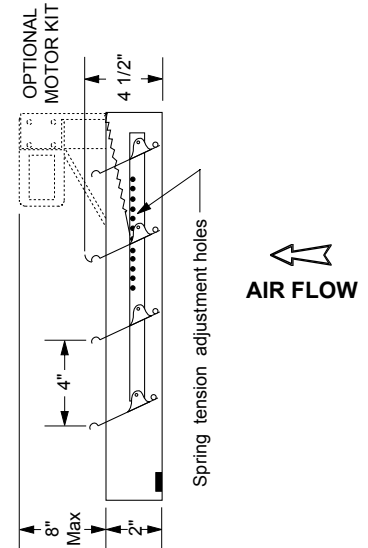

AIR FLOW

FAN SIZE	CENTRIFUGAL ROOF FANS	INLINE FANS		PROPELLER
	DB, RED, TXB, LPD, TXD	SQB	SQD	ARE
	"A" SQUARE	"A" SQUARE	"A" SQUARE	"A" SQUARE
6	11	-	9	-
7	-	12	-	-
8	11	12	12	-
9	11	-	-	-
10	11	14	14	14
11/12	18	18	18	18
14	18	-	-	-
15	18	22	20	-
16	18	-	-	22
18	24	24	-	-
20	24	28	-	26
24	30	35	-	-
30	36	40	-	-
36	36	48	-	-
42	48	54	-	-
48	48	-	-	-

**STANDARD SPECIFICATIONS:**

Maximum Face Velocity: 2250 fpm.  
Dimensions: See sizing chart  
"A" Dimension is square damper size.  
Frame: Galvanized steel, 2" Deep  
Blades: 26 gauge Mill Finish aluminum.  
Blade pivots: Stainless steel rivet at all pivot points.  
Seals: Felt between adjacent blades.  
Counter Balance: Adjustable spring tension.  
Finish: Mill.  
Max Temp: Damper 250° F  
Motor 130° F

**CAUTION:** Motor kits are not suitable for use in explosive or flammable areas or airflows.

**NOTES:**

- (1) Units are undersized 1/4" to fit in square ducts.
- (2) Do not mount fan less than 1/3 diameter of the fan from the damper.
- (3) Dampers shipped in individual cartons.
- (4) Motor kits ship loose for field installation.

ACCESSORY ITEMS	1	2	3	4	5	ACCESSORY ITEMS	1	2	3	4	5
<input type="checkbox"/>						<input type="checkbox"/>					
<input type="checkbox"/>						<input type="checkbox"/>					
<input type="checkbox"/>						<input type="checkbox"/>					
<input type="checkbox"/>						<input type="checkbox"/>					
<input type="checkbox"/>						<input type="checkbox"/>					

Project: \_\_\_\_\_ Submitted: \_\_\_\_\_  
 Customer: \_\_\_\_\_ Approved: \_\_\_\_\_  
 Location: \_\_\_\_\_